

1-800-259-6874  
www.northamericangrating.com



# North American GRATING Company

**Molded & Pultruded  
Fiberglass Grating  
Fiberglass Structural  
Shapes & Plates  
FRP & Metal Stair Treads**

Mailing Address:  
P.O. Box 1074  
Mandeville, LA 70470  
USA

Contact info:  
Phone: 1-800-259-6874  
Local: 985-893-0909  
Fax: 985-893-0807

[www.northamericangrating.com](http://www.northamericangrating.com)  
[sales@northamericangrating.com](mailto:sales@northamericangrating.com)

## Pultruded Fiberglass Grating

Pultrusion technology is a manufacturing process which produces uniform cross-sectionally shaped glass-fiber reinforced polymer composite profiles. These profiles are designed to compete with the strength properties of traditional metal grating structures, but offer the inherent environmental benefits that come with using fiberglass. The fiberglass reinforced polymer matrix is ideal for corrosive environments and greatly reduces the maintenance required over the life-time of the grating.

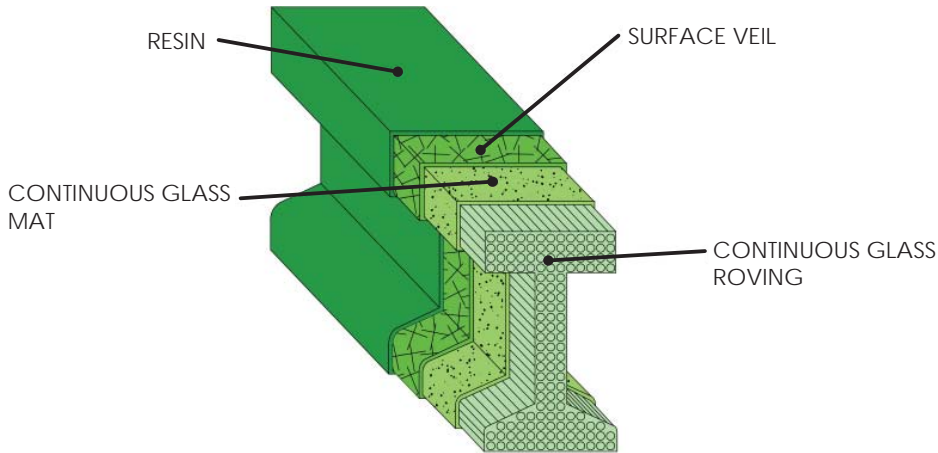

### Key Features

- Corrosion Resistant
- High Strength
- Fatigue Resistant
- Lightweight
- Easy to Fabricate & Install
- Fire Retardant
- Maintenance free
- Non-conductive
- Low Thermal Conductivity
- Slip Resistant
- Rust Free & Weather Proof
- Cost Effective
- Uniform in appearance
- UV Resistant

### Applications

Pultruded fiberglass grating is designed and used in a wide variety of applications, such as:

- Chemical Plants
- Marine/Offshore
- Petrochemical Plants
- Shipping Docks
- Pulp & Paper Mills
- Transportation Industry
- Communication Industry
- Water Treatment Plants
- Processing Plants
- Oil Rigs
- Food Processing
- Power Plants
- Mining Industry
- General Industry

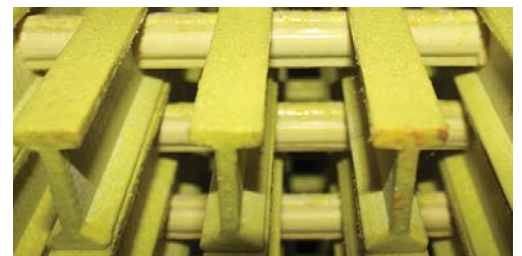

### Product Selection

Part Number	Bar Type	Thickness (in)	Size (ft)	Color	Resin Type	Open Area (%)	Bars per ft	Approx. Wt. (lb.ft <sup>2</sup> )
IG6010-PP-Y-320	I	1.0	3 x 20	Yellow	Premium Polyester	60	8	2.39
IG6010-PP-DGY-320	I	1.0	3 x 20	Gray	Premium Polyester	60	8	2.39
IG6010-PP-Y-420	I	1.0	4 x 20	Yellow	Premium Polyester	60	8	2.39
IG6010-PP-DGY-420	I	1.0	4 x 20	Gray	Premium Polyester	60	8	2.39
IG6015-PP-Y-320	I	1.5	3 x 20	Yellow	Premium Polyester	60	8	2.95
IG6015-PP-DGY-320	I	1.5	3 x 20	Gray	Premium Polyester	60	8	2.95
IG6015-PP-Y-420	I	1.5	4 x 20	Yellow	Premium Polyester	60	8	2.95
IG6015-PP-DGY-420	I	1.5	4 x 20	Gray	Premium Polyester	60	8	2.95
TG5020-PP-DGY-320	T	2.0	3 x 20	Gray	Premium Polyester	50	6	3.38
TG5020-PP-DGY-420	T	2.0	4 x 20	Gray	Premium Polyester	50	6	3.38

## Panel Dimensions

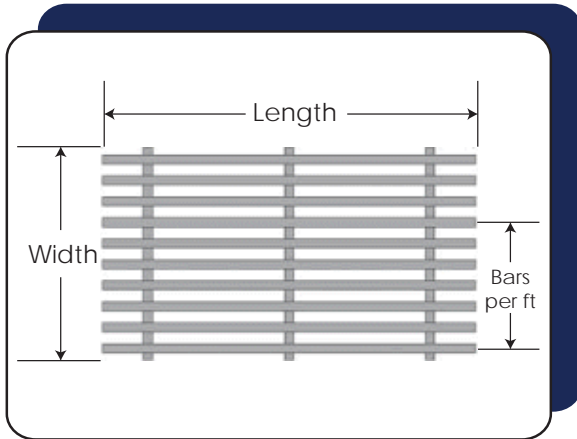

## Cross-rod System

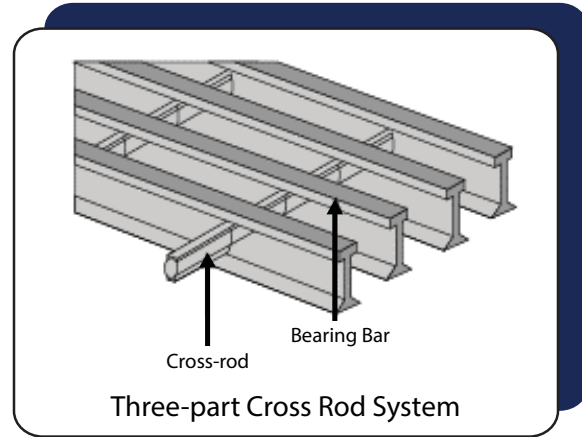

## Mechanical Properties of Pultruded Grating

Property	Test Method	I-Series (70-75% Glass)	T-Series (60-65% Glass)
Tensile Strength	ASTM D638	125,000 psi	100,000 psi
Tensile Modulus	ASTM D638	$6 \times 10^6$ psi	$5.6 \times 10^6$ psi
Flexural Strength	ASTM D790	125,000 psi	100,000 psi
Flexural Modulus	ASTM D790	$6 \times 10^6$ psi	$5.6 \times 10^6$ psi
Compressive Strength	ASTM D695	65,000 psi	60,000 psi
Izod Impact Notch	ASTM D256	40 ft-lb/in	40 ft-lb/in
Barcol Hardness	ASTM D2583	50 (min)	50 (min)
Specific Gravity	ASTM D792	2	2
Water Absorption	ASTM D570	Max 0.3%	Max 0.3%

## Resin Selection

Selecting the correct resin type is critical in providing corrosion resistance and ensuring the life-time dependability and performance of the grating. If you are unsure which resin type fits your application's needs, feel free to contact us.

**Type PP** is a premium isophthalic polyester resin. It is a popular choice for most applications due to its good corrosion resistance properties and relative low cost. This type of resin is most commonly used in applications where there is a possibility of a splash or spill of harsh chemicals.

**Type GP** is an orthophthalic polyester resin commonly used for general purpose applications. It is an ideal choice for light industrial applications and moderate corrosive environments. It offers superior protection from corrosion and rust compared with traditional metal grating. Common applications include: water treatment plants, irrigation applications, walkways and trench covers.

## Load Table

IG6010 - 1" I-BAR SPACED 1.5" ON CENTER										
SPAN INCHES		LOAD IN LBS - DEFLECTION IN INCHES								SAFE LOAD LBS
		50	100	150	200	250	500	1000	2000	
12	ΔU	<0.01	<0.01	<0.01	<0.01	<0.01	0.01	0.02	0.05	10089
	ΔC	<0.01	<0.01	<0.01	0.01	0.01	0.02	0.04	0.08	5044
18	ΔU	<0.01	<0.01	0.01	0.02	0.02	0.05	0.09	0.19	4805
	ΔC	<0.01	0.01	0.02	0.02	0.03	0.05	0.10		3605
24	ΔU	0.01	0.03	0.04	0.05	0.07	0.13			2813
	ΔC	0.01	0.02	0.03	0.04	0.05	0.10	0.21		2813
30	ΔU	0.03	0.06	0.09	0.12	0.15				1800
	ΔC	0.02	0.04	0.06	0.08	0.10	0.19	0.39		2250
36	ΔU	0.06	0.12	0.18	0.24	0.31				1250
	ΔC	0.03	0.07	0.10	0.13	0.16	0.33			1875
42	ΔU	0.11	0.22	0.33	0.44					915
	ΔC	0.05	0.10	0.15	0.20	0.25				1600
48	ΔU	0.19	0.37							697
	ΔC	0.07	0.15	0.22	0.30	0.37				1394
54	ΔU	0.30								549
	ΔC	0.11	0.21	0.32	0.42					1236

## Specifications

60% Open Area

A = 2.496 in<sup>2</sup>/ft of width

S = 0.656 in<sup>3</sup>/ft of width

I = 0.326 in<sup>4</sup>/ft of width

Approx. Wt. = 2.39 lbs/sq.ft

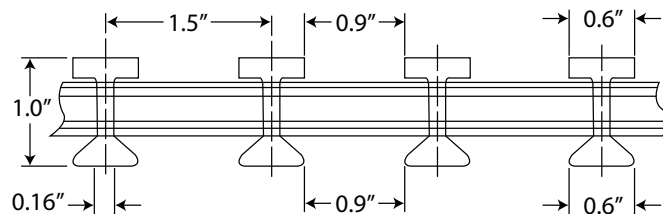

## Load Table Data

Uniform Load

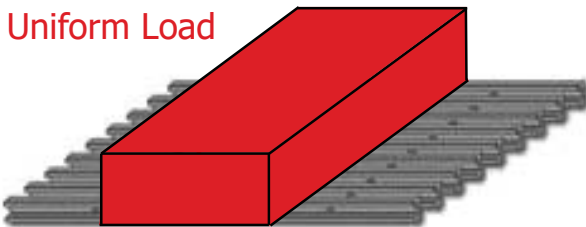

U = Uniform load - lbs/ft of width  
ΔU = Uniform load deflection (in/mm)

Concentrated Line Load

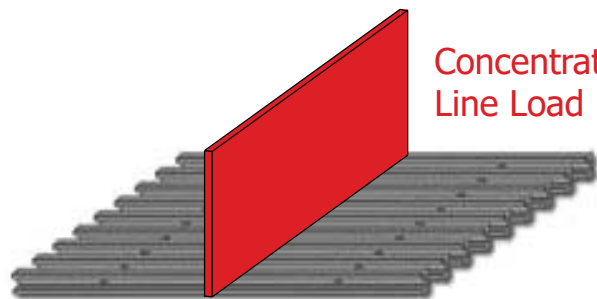

C = Concentrated line load - lbs/ft  
ΔC = Concentrated line load deflection (in/mm)

## Load Table

IG6015 - 1.5" I-BAR SPACED 1.5" ON CENTER										
SPAN INCHES		LOAD IN LBS - DEFLECTION IN INCHES								SAFE LOAD LBS
		50	100	150	200	250	500	1000	2000	
12	ΔU	<0.01	<0.01	<0.01	<0.01	<0.01	0.01	0.01	0.02	17073
	ΔC	<0.01	<0.01	<0.01	<0.01	<0.01	0.01	0.02	0.04	8536
18	ΔU	<0.01	<0.01	0.01	0.01	0.01	0.02	0.04	0.08	7588
	ΔC	<0.01	<0.01	0.01	0.01	0.01	0.02	0.04	0.08	5691
24	ΔU	0.01	0.01	0.02	0.02	0.03	0.05	0.10	0.21	4268
	ΔC	<0.01	0.01	0.01	0.02	0.02	0.04	0.08	0.17	4268
30	ΔU	0.01	0.02	0.03	0.05	0.06	0.12	0.23		2690
	ΔC	0.01	0.01	0.02	0.03	0.04	0.07	0.15	0.30	3363
36	ΔU	0.02	0.05	0.07	0.09	0.11	0.23			1839
	ΔC	0.01	0.02	0.04	0.05	0.06	0.12	0.24		2760
42	ΔU	0.04	0.08	0.12	0.17	0.21	0.41			1320
	ΔC	0.02	0.04	0.06	0.08	0.09	0.19	0.38		2310
48	ΔU	0.07	0.14	0.21	0.28	0.35				986
	ΔC	0.03	0.06	0.08	0.11	0.14	0.28			1972
54	ΔU	0.11	0.22	0.34	0.45					754
	ΔC	0.04	0.08	0.12	0.16	0.20	0.40			1696
60	ΔU	0.17	0.34							590
	ΔC	0.05	0.11	0.16	0.22					1474
66	ΔU	0.25	0.50							470
	ΔC	0.07	0.15	0.22	0.29					1293

## Specifications

60% Open Area

A = 3.136 in<sup>2</sup>/ft of width

S = 1.239 in<sup>3</sup>/ft of width

I = 0.928 in<sup>4</sup>/ft of width

Approx. Wt. = 2.95 lbs/sq.ft

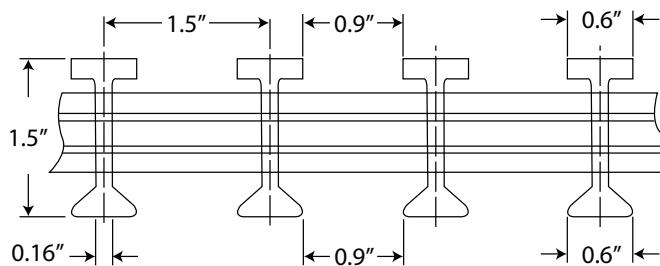

### Load Table Notes

- The designer should not exceed the recommended safe load at any time. The safe load represents a 2:1 factor of safety.
- Walking loads, typically 50 PSF is recommended for pedestrian traffic. Deflections for worker comfort are typically limited to 3/8in or SPAN divided by 120 under full loads. For a more rigid feel under full loads, limit deflection to 1/4in or SPAN divided by 200.
- The allowable loads are for static conditions at ambient temperatures. Allowable loads for impact or dynamic loads should be a maximum of 1/2 the value shown. Long term loads will likely result in added deflection due to creep in the material and will also require higher safety factors to ensure acceptable performance.

## Load Table

TG5020 - 2" T - BAR SPACED 2.0" ON CENTER										
SPAN INCHES		LOAD IN LBS - DEFLECTION IN INCHES								SAFE LOAD
		50	100	150	200	250	500	1000	2000	LBS
12	ΔU	<0.01	<0.01	<0.01	<0.01	<0.01	<0.01	0.01	0.01	10993
	ΔC	<0.01	<0.01	<0.01	<0.01	<0.01	0.01	0.02	0.02	5496
18	ΔU	<0.01	<0.01	0.00	0.01	0.01	0.01	0.03	0.03	7310
	ΔC	<0.01	<0.01	<0.01	0.01	0.01	0.01	0.03	0.04	5496
24	ΔU	<0.01	0.01	0.01	0.01	0.02	0.03	0.07	0.11	5496
	ΔC	<0.01	<0.01	0.01	0.01	0.01	0.03	0.05	0.08	5496
30	ΔU	0.01	0.01	0.02	0.03	0.04	0.07	0.14	0.25	3517
	ΔC	<0.01	0.01	0.01	0.02	0.02	0.05	0.09	0.16	4398
36	ΔU	0.01	0.03	0.04	0.06	0.07	0.14	0.28	0.52	2443
	ΔC	0.01	0.01	0.02	0.03	0.04	0.07	0.15	0.27	3665
42	ΔU	0.02	0.05	0.07	0.10	0.12	0.25			1795
	ΔC	0.01	0.02	0.03	0.05	0.06	0.11	0.23	0.44	3141
48	ΔU	0.04	0.08	0.12	0.17	0.21	0.41			1374
	ΔC	0.02	0.03	0.05	0.07	0.08	0.17	0.33	0.63	2749
54	ΔU	0.06	0.13	0.19	0.26	0.32				1086
	ΔC	0.02	0.05	0.07	0.09	0.11	0.23	0.46		2443
60	ΔU	0.10	0.2	0.29	0.39	0.49				880
	ΔC	0.03	0.06	0.09	0.13	0.16	0.31			2199
66	ΔU	0.14	0.29	0.43						727
	ΔC	0.04	0.08	0.12	0.17	0.21	0.42			1998
72	ΔU	0.20	0.40							610
	ΔC	0.05	0.11	0.16	0.22	0.27				1832
78	ΔU	0.28								520
	ΔC	0.07	0.14	0.20	0.27	0.34				1692
84	ΔU	0.37								449
	ΔC	0.09	0.17	0.26	0.34	0.43				1570

## Specifications

50% Open Area

$A = 3.253 \text{ in}^2/\text{ft}$  of width

$S_T = 1.906 \text{ in}^3/\text{ft}$  of width

$S_E = 1.496 \text{ in}^3/\text{ft}$  of width

$I = 1.676 \text{ in}^4/\text{ft}$  of width

Approx. Wt. = 3.38 lbs/sq.ft

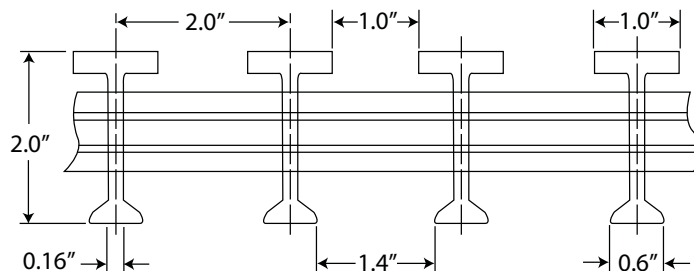

## Load Table

### RG83100 - 1.0" Cooling Tower Grating

SPAN INCHES		LOAD IN LBS - DEFLECTION IN INCHES													MAXIMUM RECOMMENDED
		50	100	150	200	300	400	500	750	1000	2000	3000	4000	5000	LBS
12	ΔU	0.002	0.003	0.005	0.008	0.011	0.015	0.018	0.027	0.035	0.068	0.103	0.137	0.173	8200
	ΔC	0.003	0.005	0.009	0.012	0.018	0.023	0.029	0.042	0.055	0.111	0.166	0.221	0.275	4100
18	ΔU	0.007	0.015	0.023	0.031	0.045	0.060	0.075	0.112	0.148	0.295	0.444	0.591	0.737	3600
	ΔC	0.008	0.017	0.025	0.032	0.046	0.064	0.078	0.119	0.158	0.314	0.471	0.631	0.788	2700
24	ΔU	0.023	0.046	0.068	0.091	0.136	0.181	0.224	0.336	0.448	0.890	1.347			2000
	ΔC	0.019	0.035	0.055	0.071	0.109	0.145	0.181	0.268	0.358	0.719	1.077	1.436		2000
30	ΔU	0.053	0.104	0.159	0.212	0.315	0.421	0.528	0.792	1.054					1280
	ΔC	0.035	0.069	0.102	0.136	0.204	0.271	0.337	0.505	0.674	1.351				1600
36	ΔU	0.107	0.212	0.318	0.521	0.634	0.845	1.055	1.582						870
	ΔC	0.057	0.114	0.170	0.224	0.337	0.450	0.562	0.844	1.127					1300
42	ΔU	0.195	0.390	0.584	0.777	1.168	1.555								630
	ΔC	0.088	0.177	0.268	0.355	0.534	0.712	0.888	1.332						1100
48	ΔU	0.331	0.662	0.992	1.323										500
	ΔC	0.133	0.264	0.398	0.530	0.794	1.058	1.323							1000
54	ΔU	0.525	1.054	1.579											400
	ΔC	0.188	0.376	0.562	0.750	1.122	1.498								900

A = 2.003IN<sup>2</sup>/FT Of Width

I = .0166 IN<sup>4</sup>/FT Of Width

S = 0.332 IN<sup>3</sup>/FT Of Width

83% Open Area

Approx Weight = 2.2 Lbs/Sq Ft

## Dimensional Details

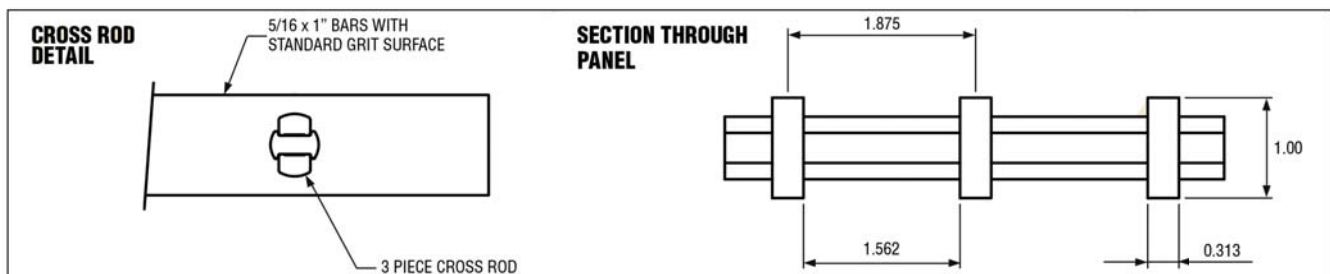

## Chemical Resistance Chart for Fiberglass Grating

Chemical	Resin Type: Premium Polyester		Chemical	Resin Type: Premium Polyester	
	Concentration %	Max Operating Temperature °F/°C		Concentration %	Max Operating Temperature °F/°C
Acetic Acid	50	125/52	Lithium Chloride	SAT	150/66
Aluminum Hydroxide	100	160/71	Magnesium Chloride	ALL	170/77
Ammonium Chloride	ALL	170/77	Magnesium Nitrate	ALL	140/60
Ammonium Hydroxide	28	N/R	Magnesium Sulfate	ALL	170/77
Ammonium Bicarbonate	15	125/52	Mercuric Chloride	100	150/66
Ammonium Sulfate	ALL	170/77	Mercurous Chloride	ALL	140/60
Benzene	N/R	N/R	Nickel Chloride	ALL	170/77
Benzoic Acid	SAT	150/66	Nickel Sulfate	ALL	170/77
Borax	SAT	170/77	Nitric Acid	20	70/21
Calcium Carbonate	ALL	170/77	Oxalic Acid	ALL	75/24
Calcium Nitrate	ALL	180/82	Perchloric Acid	N/R	N/R
Carbon Tetrachloride	N/R	N/R	Phosphoric Acid	100	120/49
Chlorine (Dry Gas)	-	140/60	Potassium Chloride	ALL	170/77
Chlorine (Water)	SAT	80/27	Potassium Dichromate	ALL	170/77
Chromic Acid	5	70/21	Potassium Nitrate	ALL	170/77
Citric Acid	ALL	170/77	Potassium Sulfate	ALL	170/77
Copper Chloride	ALL	170/77	Propylene Glycol	ALL	170/77
Copper Cyanide	ALL	170/77	Sodium Acetate	ALL	160/71
Copper Nitrate	ALL	170/77	Sodium Bisulfate	ALL	170/77
Ethanol	50	75/24	Sodium Bromide	ALL	170/77
Ethylene Glycol	100	90/32	Sodium Cyanide	ALL	170/77
Ferric Chloride	ALL	170/77	Sodium Hydroxide	N/R	N/R
Ferrous Chloride	ALL	170/77	Sodium Nitrate	ALL	170/77
Formaldehyde	50	75/24	Sodium Sulfate	ALL	170/77
Gasoline	100	80/27	Stannic Chloride	ALL	160/71
Glucose	100	170/77	Sulfuric Acid	25	75/24
Glycerine	100	150/66	Tartaric Acid	ALL	170/77
Hydrobromic Acid	50	120/49	Vinegar	100	170/77
Hydrochloric Acid	37	75/24	Water (Distilled)	100	170/77
Hydrogen Peroxide	5	100/38	Zinc Nitrate	ALL	170/77
Lactic Acid	ALL	170/77	Zinc Sulfate	ALL	170/77

ALL - All Concentrations    SAT - Saturated Solution    N/R - Not Recommended    '-' No Information Available

### ■ Notes

The chemical resistance chart is to be used as a general reference guide. Resin manufacturers have provided data which indicates that specific resins can withstand the corrosion conditions listed. Testing for specific environments is recommended if the environment is unknown. North American Grating believes the following data to be true and accurate but does not guarantee expressed or implied performance from the data presented.



## Clips & Accessories

### Saddle Clips

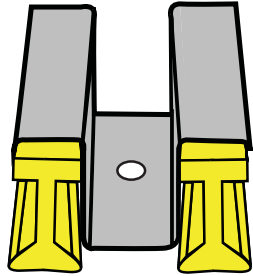

Model: SSC & STC

#### Sizes

1"	SSC10
1-1/2"	SSC15
2"	STC20

- 316 Stainless Steel
- Typically used for attaching grating to structural supports and joining two panels together
- Available in 3 sizes
- Model SSC is used for I-Bar grating
- Model STC is used for T-Bar grating

### Curb Angle

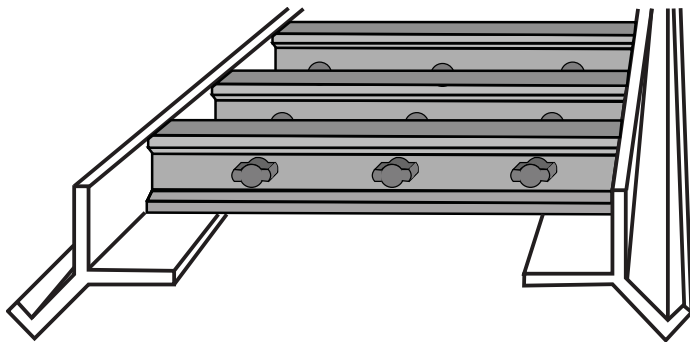

- Pultruded Fiberglass curb angle
- Provides a strong and sturdy base for pultruded grating
- Typically used in drainage, irrigation and structural applications
- Available in 3 sizes



## Molded Fiberglass Grating

Molded fiberglass grating provides a cost effective solution and long lasting performance for many industrial and recreational applications. Fiberglass offers superior strength and durability in corrosive environments compared to traditional metal grating.

Molded grating is constructed in one piece from continuous fiberglass rovings and a wide range of premium polyesters or vinyl ester resins. A unique three step weaving process ensures that all glass reinforcements are lined up in the center of bars and protected by the outer resin layers. All grating is tested by independent third-party companies to testing standards set forth by the Fiberglass Grating Manufacturers Council.

Quality and customer service are what set North American Grating above everyone else. We strive to offer a level of customer service that exceeds the customer's expectations. Located in Abita Springs, Louisiana we offer expedited delivery on all stock items being shipped domestically.

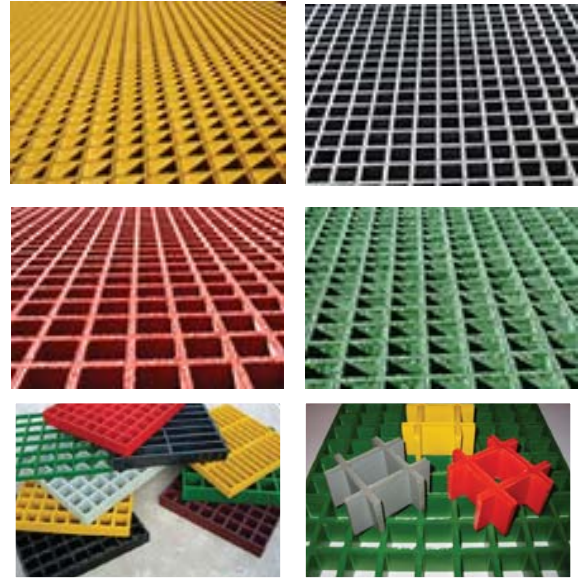

## Applications

- Chemical Plants
- Marine/Offshore
- Petrochemical Plants
- Agricultural
- Pulp & Paper Mills
- Water Treatment Plants
- Processing Plants
- Oil Rigs
- Food Processing
- Power Plants
- Brewing & Distillery
- Pigments & Dyes
- Fisheries
- Chemical Fertilizers
- Sewage Treatment Plants
- Air Pollution Control
- Caustic & Chlorine

## Stock Panel Selection

\* Other grating profiles and panel sizes available upon request.

Part Number	Thickness (in)	Mesh Size (in)	Panel Size (ft)	Color	Resin Type	Surface Finish
MG1015-PP-Y-310	1.0	1.5 X 1.5	3 X 10	Yellow	Premium Polyester	Concave or Gritted
MG1015-PP-DGY-310	1.0	1.5 X 1.5	3 X 10	Dark Gray	Premium Polyester	Concave or Gritted
MG1015-PP-Y-48	1.0	1.5 X 1.5	4 X 8	Yellow	Premium Polyester	Concave or Gritted
MG1015-PP-DGY-48	1.0	1.5 X 1.5	4 X 8	Dark Gray	Premium Polyester	Concave or Gritted
MG1015-PP-Y-412	1.0	1.5 X 1.5	4 X 12	Yellow	Premium Polyester	Concave or Gritted
MG1015-PP-DGY-412	1.0	1.5 X 1.5	4 X 12	Dark Gray	Premium Polyester	Concave or Gritted
MG1515-PP-Y-310	1.5	1.5 X 1.5	3 X 10	Yellow	Premium Polyester	Concave or Gritted
MG1515-PP-DGY-310	1.5	1.5 X 1.5	3 X 10	Dark Gray	Premium Polyester	Concave or Gritted
MG1515-PP-Y-48	1.5	1.5 X 1.5	4 X 8	Yellow	Premium Polyester	Concave or Gritted
MG1515-PP-DGY-48	1.5	1.5 X 1.5	4 X 8	Dark Gray	Premium Polyester	Concave or Gritted
MG1515-PP-Y-412	1.5	1.5 X 1.5	4 X 12	Yellow	Premium Polyester	Concave or Gritted
MG1515-PP-DGY-412	1.5	1.5 X 1.5	4 X 12	Dark Gray	Premium Polyester	Concave or Gritted
MG2020-PP-Y-GT-412	2.0	2.0 X 2.0	4 X 12	Yellow	Premium Polyester	Gritted

\* Vinyl ester & general polyester resin available by request.

## Key Features

### Corrosion & Chemical Resistant

Molded grating is manufactured with continuous glass fiber strands wetted thoroughly with premium grade polyester resin. Such inherent characteristics ensure excellent corrosion resistance over a wide pH range both acidic and caustic.

### Great Tensile Strength

A three step continuous fiberglass strand alternating layers and ultimate one piece construction distributes loads to bi-directional bars for greater tensile strength.

### Impact Resistant

Unlike metallic grating which will deform and need replacement over time, impact resistance fiberglass grating allows for repeated deflections without permanent deformation.

### Fire Retardant

All molded grating resins have a class 1 flame spread rate of 25 or less, per ASTM E84.

### Non-Conductive

Molded grating is ideal for electrically hazardous locations. Its inherent properties reduce the risk of electrical shock by acting as an insulator between conductive materials.

### Slip Resistant

Two different surface types are available to offer maximum slip resistance for any application. The built-in concave surface offers adequate protection for most applications. The grit surface will provide excellent slip resistance and last longer from normal wear and tear.

### Non- Magnetic

Molded grating can be used in sensitive areas where the inherent magnetic properties of traditional metal grating could prove lethal.

### Non-Sparking

Molded grating is well suited for applications in which sparks may trigger explosions or fires due to build-up of combustible gases.

### Maintenance Free

Molded grating offers a maintenance free alternative to metallic grating due to its inherent ultraviolet resistance characteristics and corrosion/rust resistance properties.

### Easy Installation & Fabrication

Molded grating weights about one-fourth that of traditional metal grating. This makes installation and fabrication easily accomplished with no more than two people and standard equipment.

## Color Selection



Yellow



Dark Gray



Orange



Green

## Surface Selection



Concave

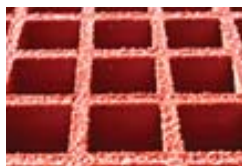

Gritted

## Load Table

MG1015 - 1.0" THICK 1.5" x 1.5" SQUARE MESH													
SPAN INCHES		LOAD IN LBS - DEFLECTION IN INCHES										MAXIMUM RECOMMENDED	ULTIMATE CAPACITY
		50	100	150	200	300	400	600	800	1000	1200	LBS	LBS
12	ΔU	0.004	0.009	0.013	0.018	0.026	0.037	0.051	0.073	0.089	0.100	1350	6750
	ΔC	0.008	0.015	0.021	0.026	0.042	0.054	0.083	0.106	0.138	0.165	670	3350
18	ΔU	0.022	0.042	0.063	0.083	0.124	0.165	0.243	0.325	0.406	0.485	650	3250
	ΔC	0.023	0.045	0.067	0.089	0.132	0.178	0.260	0.355	0.437	0.518	498	2490
24	ΔU	0.063	0.127	0.193	0.256	0.386	0.511	0.770				377	1885
	ΔC	0.051	0.101	0.153	0.203	0.307	0.411	0.612				377	1885
30	ΔU	0.154	0.308	0.463	0.618							235	1175
	ΔC	0.098	0.196	0.296	0.394	0.595						297	1485
36	ΔU	0.312	0.629									158	790
	ΔC	0.167	0.337	0.501	0.668							237	1185

## Specifications

Number of bars per ft = 8

Load bar thickness = 0.26" / 0.2"

Load bar center-to-center = 1.5"

Cross bar thickness = 0.26" / 0.2"

Cross bar center-to-center = 1.5"

Open Area = 68%

Approx. Weight = 2.5 lbs/ft<sup>2</sup>

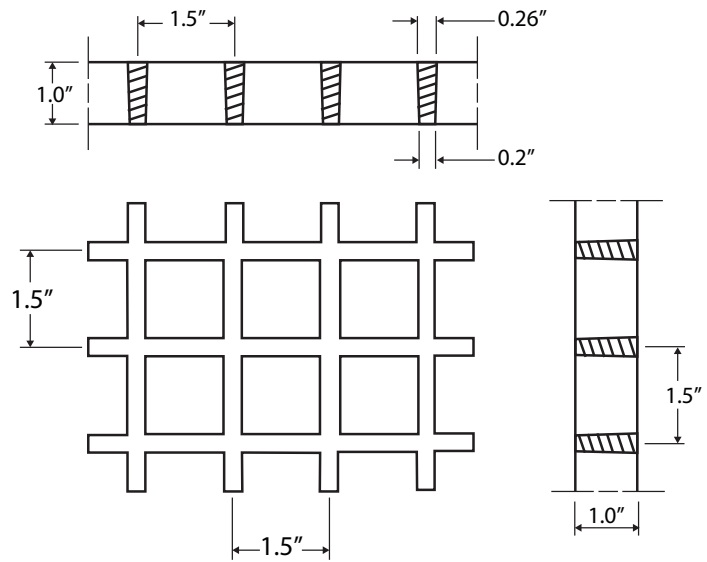

## Load Table Data

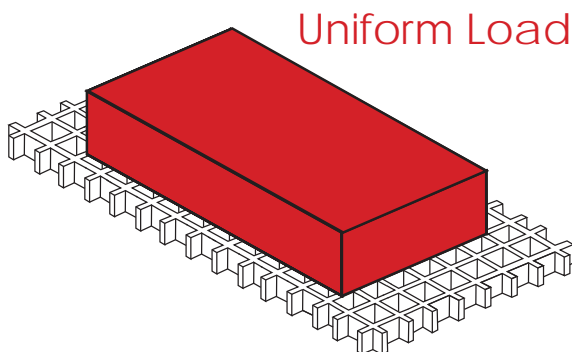

Uniform Load

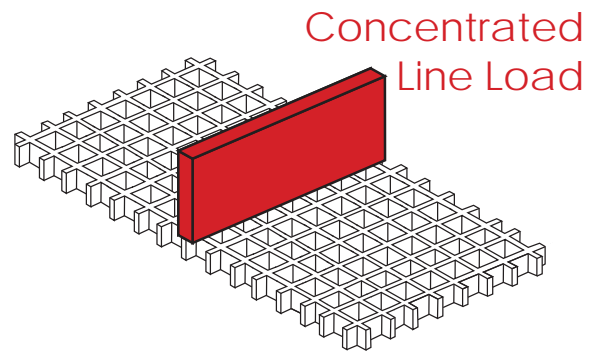

Concentrated Line Load

U = Uniform load - lbs/ft of width  
 ΔU = Uniform load deflection (in/mm)

C = Concentrated line load - lbs/ft  
 ΔC = Concentrated line load deflection (in/mm)

## Load Table

### MG1515 - 1.5" THICK 1.5" x 1.5" SQUARE MESH

SPAN INCHES		LOAD IN LBS - DEFLECTION IN INCHES										MAXIMUM RECOMMENDED	ULTIMATE CAPACITY
		50	100	150	200	300	400	600	800	1000	1200	LBS	LBS
12	ΔU	0.002	0.005	0.006	0.009	0.012	0.017	0.023	0.033	0.041	0.045	2070	10350
	ΔC	0.003	0.007	0.009	0.012	0.017	0.023	0.032	0.045	0.055	0.062	1550	7750
18	ΔU	0.008	0.015	0.022	0.029	0.044	0.057	0.085	0.111	0.142	0.166	1370	6850
	ΔC	0.009	0.017	0.025	0.032	0.048	0.062	0.090	0.119	0.149	0.178	1030	5150
24	ΔU	0.022	0.042	0.064	0.086	0.126	0.165	0.248	0.331	0.415	0.494	775	3875
	ΔC	0.016	0.032	0.048	0.063	0.095	0.125	0.188	0.252	0.312	0.388	775	3875
30	ΔU	0.046	0.093	0.140	0.188	0.283	0.377	0.565	0.751			491	2455
	ΔC	0.029	0.060	0.090	0.120	0.180	0.239	0.359	0.479	0.588	0.718	615	3075
36	ΔU	0.094	0.189	0.282	0.382	0.571	0.759					338	1690
	ΔC	0.049	0.099	0.149	0.199	0.299	0.399	0.588				516	2580
42	ΔU	0.173	0.347	0.519								248	1240
	ΔC	0.078	0.155	0.239	0.312	0.468	0.618					438	2190
48	ΔU	0.278	0.569									168	840
	ΔC	0.112	0.225	0.333	0.449	0.672						338	1690

## Specifications

Number of bars per ft = 8

Load bar thickness = 0.28" / 0.2"

Load bar center-to-center = 1.5"

Cross bar thickness = 0.28" / 0.2"

Cross bar center-to-center = 1.5"

Open Area = 67%

Approx. Weight = 3.8 lbs/ft<sup>2</sup>

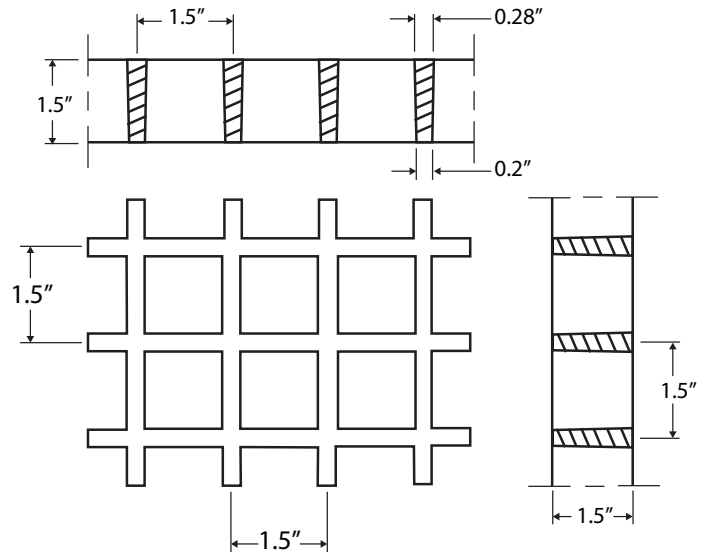

## Load Table

### MG2020 - 2.0" THICK 2.0" x 2.0" SQUARE MESH

SPAN INCHES		LOAD IN LBS - DEFLECTION IN INCHES										MAXIMUM RECOMMENDED	ULTIMATE CAPACITY
		50	100	150	200	300	400	600	800	1000	1200	LBS	LBS
12	ΔU	0.001	0.002	0.003	0.004	0.006	0.008	0.011	0.015	0.020	0.023	2170	10830
	ΔC	0.002	0.004	0.006	0.009	0.011	0.017	0.023	0.032	0.039	0.043	1630	8250
18	ΔU	0.004	0.009	0.013	0.017	0.025	0.032	0.049	0.063	0.083	0.095	1388	7940
	ΔC	0.004	0.010	0.014	0.019	0.027	0.037	0.053	0.071	0.091	0.105	1356	6780
24	ΔU	0.011	0.022	0.033	0.043	0.065	0.083	0.125	0.163	0.211	0.245	956	4780
	ΔC	0.008	0.016	0.023	0.031	0.047	0.062	0.095	0.131	0.158	0.189	956	4780
30	ΔU	0.022	0.044	0.065	0.089	0.128	0.183	0.262	0.363	0.439	0.522	637	3185
	ΔC	0.014	0.027	0.042	0.058	0.086	0.117	0.174	0.231	0.291	0.346	792	3960
36	ΔU	0.043	0.083	0.133	0.177	0.266	0.354	0.530	0.707			458	2290
	ΔC	0.025	0.049	0.071	0.095	0.141	0.189	0.282	0.375	0.471	0.562	677	3385
42	ΔU	0.080	0.163	0.245	0.328	0.489	0.653					338	1690
	ΔC	0.035	0.072	0.109	0.148	0.223	0.289	0.445	0.595			577	3885
48	ΔU	0.132	0.266	0.401	0.532							259	1295
	ΔC	0.049	0.106	0.157	0.211	0.312	0.422	0.626				517	2585
54	ΔU	0.205	0.416	0.622								200	1000
	ΔC	0.071	0.144	0.222	0.194	0.444	0.588					457	2285

## Specifications

Number of bars per ft = 6

Load bar thickness = 0.33" / 0.23"  
(Top/Bottom)

Load bar center-to-center = 2.0"

Cross bar thickness = 0.33" / 0.23"

Cross bar center-to-center = 2.0"

Open Area = 69%

Approx. Weight = 5.3 lbs/ft<sup>2</sup>

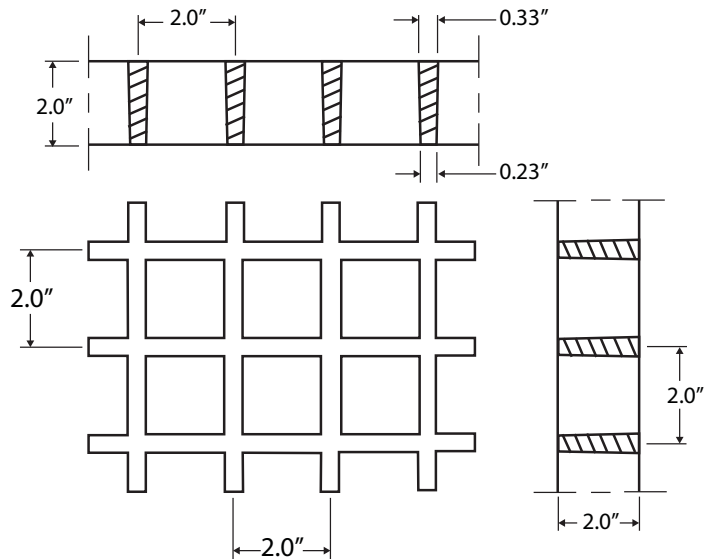

## Resin Selection

**Type VE** is a vinyl ester resin specifically engineered to provide premium service in highly corrosive environments. It utilizes an advanced resin system which delivers outstanding resistance to a wide range of harsh corrosive environments ranging from acidic to caustic. Vinyl ester resin also offers a high level of solvent resistance. It has a Class 1 flame spreading rate of 25 or less according to the ASTM E84 standard method for surface burning. Vinyl Ester is a popular choice for most applications due to its excellent corrosion resistance properties and relative low cost.

**Type PP** is a premium isophthalic polyester resin. It is a popular choice for most applications due to its good corrosion resistance properties and relative low cost. This type of resin is most commonly used in applications where there is a possibility of a splash or spill of harsh chemicals.

## Clips & Accessories

### M-Clips

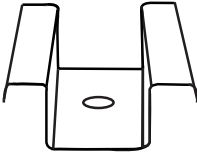

Sizes	
1"	SMC10
1-1/2"	SMC15
2"	SMC20

Model: SMC

- 316 Stainless Steel
- Typically used for attaching grating to structural supports
- Available in 3 sizes

### J-Clips

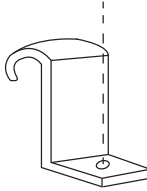

Sizes	
1"	SJC10
1-1/2"	SJC15
2"	SJC20

Model: SJC

- 316 Stainless Steel
- Typically used for attaching grating to structural supports for light to moderate loads
- Available in 3 sizes

### C-Clips

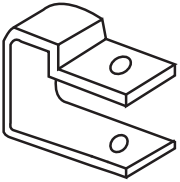

Sizes	
1"	SCC10
1-1/2"	SCC15
2"	SCC20

Model: SCC

- 316 Stainless Steel
- Typically used for joining two panels together
- Available in 3 sizes

### Curb Angle

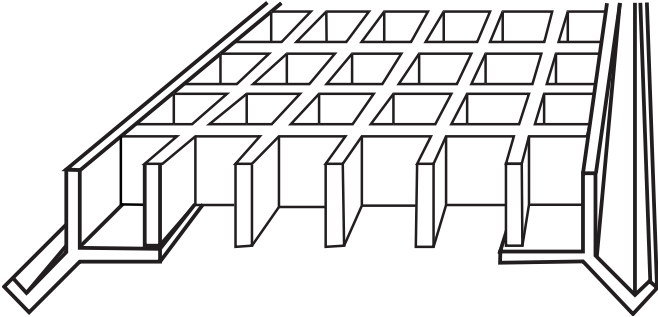

#### Features

- Pultruded Fiberglass curb angle
- Provides a strong and sturdy base for molded grating
- Typically used in drainage and structural applications
- Available in 3 sizes

## Fiberglass Stair Tread Covers

Stair tread covers are a convenient way to provide a solid, slip resistant footing for existing wood, concrete, or metal steps. Manufactured with a gritted surface, these stair tread covers offer safety and durability to existing stairs at an affordable price. Offered in a variety of widths and colors, these stair tread covers provide a low maintenance option ideal for marine, industrial & commercial applications. All stair tread covers can be supplied custom cut to the customer's specifications or in standard lengths of 12'.

## Key Features

- Slip Resistant
- Light Weight
- Low Maintenance
- Easy to Fabricate & Install
- Low Installation Cost
- Corrosion Resistant
- Excellent Durability
- Low Conductivity
- Long Service Life

Part Number	Thickness (in)	Resin	Surface	Color	Width (in)	Length (ft)	Availability
PTC125-PP-GT-BY-812	0.125	Premium Polyester	Gritted	Black & Yellow	8	12	Stock
PTC125-PP-GT-Y-812	0.125	Premium Polyester	Gritted	Yellow	8	12	Stock
PTC125-PP-GT-BY-912	0.125	Premium Polyester	Gritted	Black & Yellow	9	12	Stock
PTC125-PP-GT-Y-912	0.125	Premium Polyester	Gritted	Yellow	9	12	Stock
PTC125-PP-GT-BY-1012	0.125	Premium Polyester	Gritted	Black & Yellow	10	12	Non Stock
PTC125-PP-GT-Y-1012	0.125	Premium Polyester	Gritted	Yellow	10	12	Non Stock
PTC125-PP-GT-BY-1112	0.125	Premium Polyester	Gritted	Black & Yellow	11	12	Stock
PTC125-PP-GT-Y-1112	0.125	Premium Polyester	Gritted	Yellow	11	12	Stock
PTC250-PP-GT-BY-812	0.250	Premium Polyester	Gritted	Black & Yellow	8	12	Non Stock
PTC250-PP-GT-Y-812	0.250	Premium Polyester	Gritted	Yellow	8	12	Non Stock
PTC250-PP-GT-BY-912	0.250	Premium Polyester	Gritted	Black & Yellow	9	12	Non Stock
PTC250-PP-GT-Y-912	0.250	Premium Polyester	Gritted	Yellow	9	12	Non Stock
PTC250-PP-GT-BY-1012	0.250	Premium Polyester	Gritted	Black & Yellow	10	12	Non Stock
PTC250-PP-GT-Y-1012	0.250	Premium Polyester	Gritted	Yellow	10	12	Non Stock
PTC250-PP-GT-BY-1112	0.250	Premium Polyester	Gritted	Black & Yellow	11	12	Non Stock
PTC250-PP-GT-Y-1112	0.250	Premium Polyester	Gritted	Yellow	11	12	Non Stock





## Molded Stair Treads

Molded stair treads offer the same great advantages that come with molded grating. Available in both a square mesh and rectangular mesh with a 1.5" nosing, these stair treads are easy to install and require little to no maintenance. All stair treads come standard with a gritted, non-slip surface.

Mesh (in)	Thickness (in)	Width (in)	Length (ft)	Maximum Span for 300 lbs @ Mid-span		Open Area	Panel Weight
				1/8" or less deflection	1/4" or less deflection		
1.5 x 1.5	1.5	22	10	30	37	69%	75
1.5 x 6	1.5	22	10	30	37	67%	60



Part Number	Thickness (in)	Resin	Surface	Color	Width (in)	Length (ft)	Availability
MT1515-PP-DGY-2210	1.5	Premium Polyester	Gritted	Dark Gray	22	10	Stock
MT1515-PP-Y-2210	1.5	Premium Polyester	Gritted	Yellow	22	10	Stock
MT1516-PP-DGY-2210	1.5	Premium Polyester	Gritted	Dark Gray	22	10	Non Stock
MT1516-PP-Y-2210	1.5	Premium Polyester	Gritted	Yellow	22	10	Non Stock

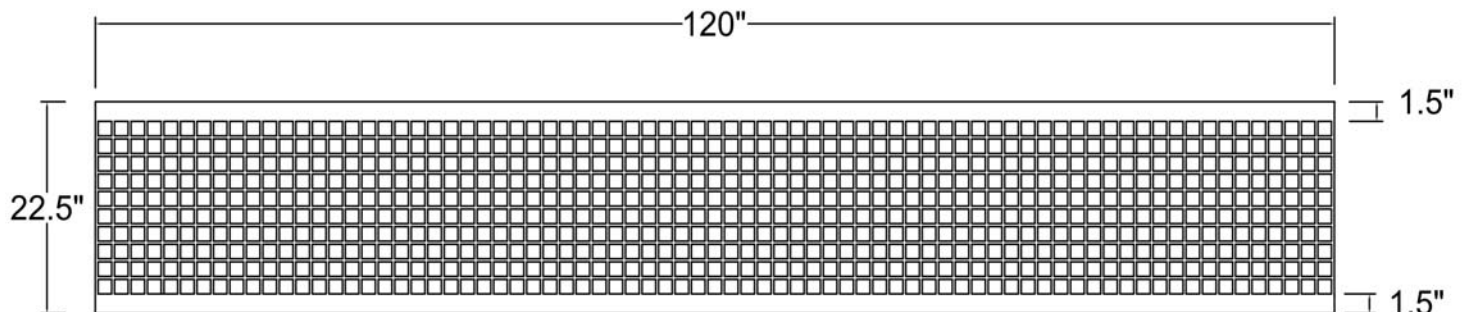

## Pultruded Stair Treads

Pultruded stair treads offer the same level of safety, strength and corrosion resistance that comes standard with pultruded grating. Superior in strength compared to molded stair treads, these treads are designed for applications where wider support spans are required. These treads are offered in a variety of colors and depths of 1", 1-1/2" and 2". All pultruded treads can be supplied custom cut to meet the customer's specifications or in standard lengths of 12'. All stair treads come standard with a gritted, non-slip surface.

Thickness (in)	Width (in)	Length (ft)	Maximum Span for 300 lbs @ Mid-span	
			1/8" or less	1/4" or less
1	11	12	28	36
1.5	11	12	39	51
2	12	12	46	58



Part Number	Thickness (in)	Resin	Surface	Color	Width (in)	Length (ft)	Availability
PT6010-PP-DGY-1112	1	Premium Polyester	Gritted	Dark Gray	11	12	Non Stock
PT6010-PP-Y-1112	1	Premium Polyester	Gritted	Yellow	11	12	Non Stock
PT6015-PP-DGY-1112	1.5	Premium Polyester	Gritted	Dark Gray	11	12	Stock
PT6015-PP-Y-1112	1.5	Premium Polyester	Gritted	Yellow	11	12	Stock
PT6015-PH-B-1112	1.5	Phenolic	Gritted	Brown	11	12	Non Stock
PT5020-PP-DGY-1212	2.0	Premium Polyester	Gritted	Dark Gray	12	12	Non Stock
PT5020-PP-Y-1212	2.0	Premium Polyester	Gritted	Yellow	12	12	Non Stock

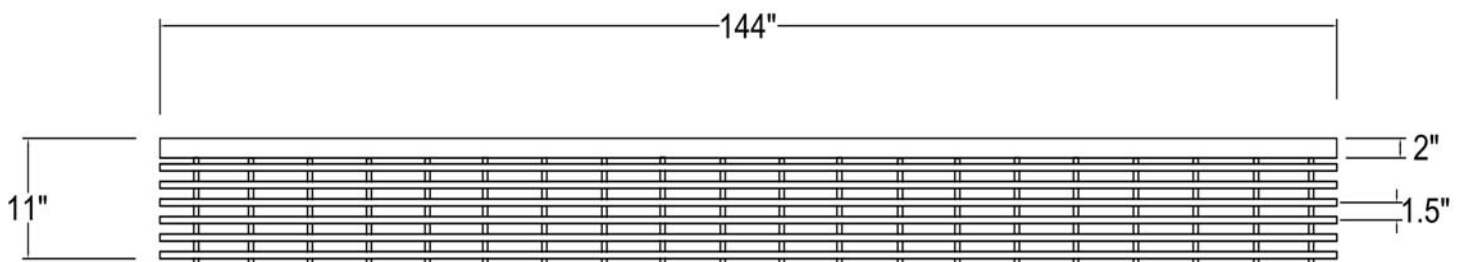

## Fiberglass Structural Shapes & Plate

North American Grating's Fiberglass Structural Shapes are manufactured to the highest quality providing excellent strength and durability. Offered in a variety of colors and sizes, these pultruded FRP shapes are more affordable and will last longer than traditional building materials.

All FIBERSHAPES are manufactured with fire retardant polyester resins that meet ASTM E84 and D635 standards. Most structural shapes are produced in standard lengths of 20' or 24' with a dark gray color, however custom sizes and colors are available upon request.

Fiberglass is the material of choice around the world because of its ability to withstand enormous loads without failure in corrosive environments. North American Grating's structural shapes out perform other competing brands and lead the industry in mechanical strength and durability.



## Key Features

- Corrosion Resistant
- High Strength
- Low Maintenance
- Easy to Install
- Lightweight (80% lighter than steel)
- Excellent Durability
- Low Conductivity
- Non-Sparking
- Fire Retardant
- Meets ASTM D635 & E84 Requirements
- Standard 12-mil surface veil



## Select Markets

- |  |  |  |
|--|--|--|
| <ul style="list-style-type: none"> <li>• Cooling Towers</li> <li>• Architecture Solutions</li> <li>• Highway Signs</li> <li>• Utility Markers</li> <li>• Snow Markers</li> <li>• Marine/Offshore</li> <li>• Transportation/Automotive</li> </ul> | <ul style="list-style-type: none"> <li>• Hand Rails</li> <li>• Stairs &amp; Accessways</li> <li>• Oil &amp; Gas</li> <li>• Chemical</li> <li>• Pulp &amp; Paper</li> <li>• Mining</li> <li>• Telecommunications</li> </ul> | <ul style="list-style-type: none"> <li>• Agriculture</li> <li>• Hand Tools</li> <li>• Recreation &amp; Waterparks</li> <li>• Electrical</li> <li>• Commercial/Residential Construction</li> <li>• Water &amp; Wastewater</li> <li>• Custom Applications</li> </ul> |
|--|--|--|

## Equal Leg Angle

Part Number	Size (in)	t (in)	L1 (in)	L2 (in)
PS-LA150250	1-1/2 x 1-1/2 x 1/4	0.250	1.5	1.5
PS-LA200250	2 x 2 x 1/4	0.250	2.0	2.0
PS-LA300250	3 x 3 x 1/4	0.250	3.0	3.0
PS-LA300375	3 x 3 x 3/8	0.375	3.0	3.0
PS-LA400250	4 x 4 x 1/4	0.250	4.0	4.0
PS-LA400375	4 x 4 x 3/8	0.375	4.0	4.0
PS-LA600500	6 x 6 x 1/2	0.500	6.0	6.0

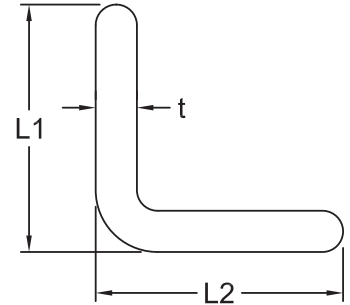

## C-Channel

Part Number	Size (in)	t (in)	L1 (in)	L2 (in)
PS-CC275125	2-3/4 x 1 x 1/8	0.125	2.75	1.00
PS-CC350187	3-1/2 x 1-1/2 x 3/16	0.187	3.50	1.50
PS-CC550250	5-1/2 x 1-1/2 x 1/4	0.250	5.50	1.50
PS-CC600375	6 x 1-11/16 x 3/8	0.375	6.00	1.69
PS-CC100050	10 x 2-3/4 x 1/2	0.500	10.00	2.75

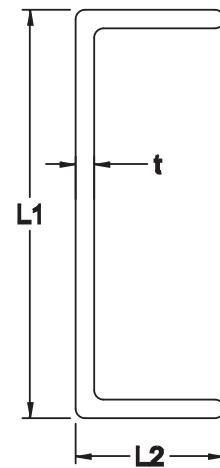

## I-Beam

Part Number	Size (in)	t (in)	L1 (in)	L2 (in)
PS-IB350187	3-1/2 x 1-1/2 x 3/16	0.187	3.50	1.50
PS-IB400250	4 x 2 x 1/4	0.250	4.00	2.00
PS-IB550250	5-1/2 x 2-1/2 x 1/4	0.250	5.50	2.50

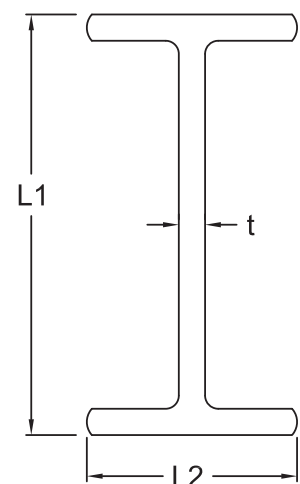

## H-Beam

Part Number	Size (in)	t (in)	L1 (in)	L2 (in)
PS-HB300250	3 x 3 x 1/4	0.250	3.0	3.0
PS-HB400250	4 x 4 x 1/4	0.250	4.0	4.0
PS-HB600250	6 x 6 x 1/4	0.250	6.0	6.0
PS-HB600375	6 x 6 x 3/8	0.375	6.0	6.0

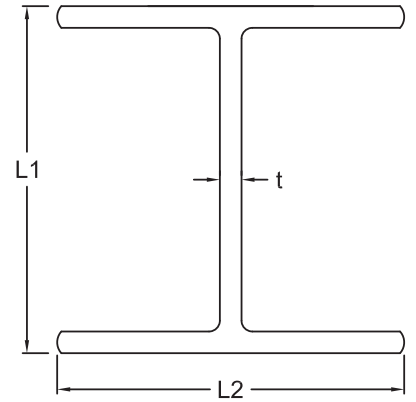

## Square Tube

Part Number	Size (in)	t (in)	L1 (in)
PS-ST100125	1 x 1 x 1/8	0.125	1.00
PS-ST100250	1 x 1 x 1/4	0.250	1.00
PS-ST125125	1-1/4 x 1-1/4 x 1/8	0.125	1.25
PS-ST150125	1-1/2 x 1-1/2 x 1/8	0.125	1.50
PS-ST200250	2 x 2 x 1/4	0.250	2.00
PS-ST250250	2-1/2 x 2-1/2 x 1/4	0.250	2.50
PS-ST300250	3 x 3 x 1/4	0.250	3.00
PS-ST350250	3-1/2 x 3-1/2 x 1/4	0.250	3.50
PS-ST400250	4 x 4 x 1/4	0.250	4.00

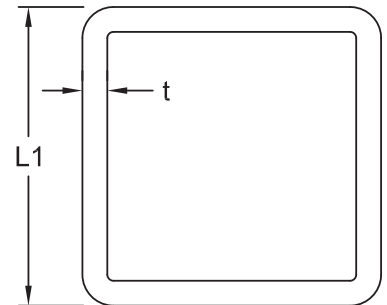

## Round Tube

Part Number	Size (in)	t (in)	L1 (in)
PS-RT100125	1 x 1/8	0.125	1.00
PS-RT125125	1-1/4 x 1/8	0.125	1.25
PS-RT150250	1-1/2 x 1/4	0.250	1.50
PS-RT175250	1-3/4 x 1/4	0.250	1.75
PS-RT200250	2 x 1/4	0.250	2.00
PS-RT300250	3 x 1/4	0.250	3.00

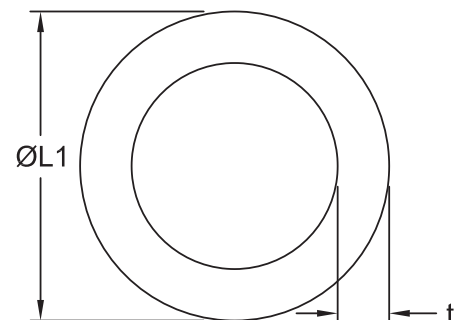

## Curb Angle Spec Sheet

1" Curb Angle

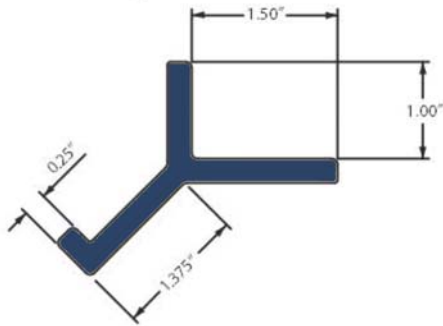

1 1/2" Curb Angle

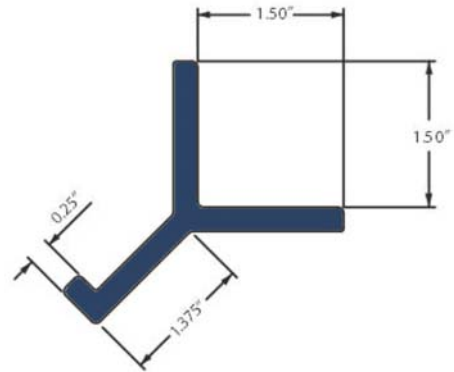

2" Curb Angle

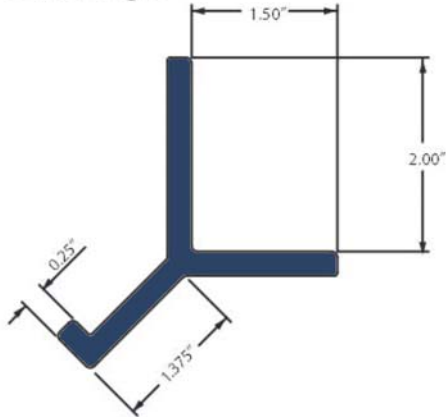

4" Curb Angle

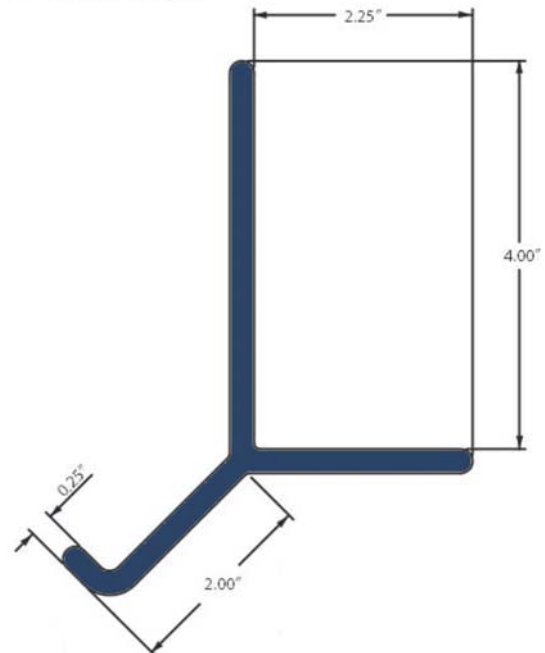

## Material Properties

The test results shown below are for typical coupon properties of FIBERSHAPES structural fiberglass shapes and plate. Properties are derived per the ASTM method shown. Synthetic surfacing veil and ultraviolet inhibitors are standard.

Mechanical Properties	ASTM	Units	Value
Tensile Stress, <i>LW</i>	D-638	psi/MPa	30,000/206.8
Tensile Stress, <i>CW</i>	D-638	psi/MPa	7,000/48.2
Tensile Modulus, <i>LW</i>	D-638	10 <sup>6</sup> psi/GPa	2.5/17.2
Tensile Modulus, <i>CW</i>	D-638	10 <sup>6</sup> psi/GPa	0.8/5.5
Compressive Stress, <i>LW</i>	D-695	psi/MPa	30,000/206.8
Compressive Stress, <i>CW</i>	D-695	psi/MPa	15,000/103.4
Compressive Modulus, <i>LW</i>	D-695	10 <sup>6</sup> psi/GPa	2.5/17.2
Compressive Modulus, <i>CW</i>	D-695	10 <sup>6</sup> psi/GPa	1.0/6.9
Flexural Stress, <i>LW</i>	D-790	psi/MPa	30,000/206.8
Flexural Stress, <i>CW</i>	D-790	psi/MPa	10,000/68.9
Flexural Modulus, <i>LW</i>	D-790	10 <sup>6</sup> psi/GPa	2.5/17.2
Flexural Modulus, <i>CW</i>	D-790	10 <sup>6</sup> psi/GPa	0.8/5.5
Modulus of Elasticity	Full Section	10 <sup>6</sup> psi/GPa	2.8/19.3
Shear Modulus	-	10 <sup>6</sup> psi/GPa	0.45/3.1
Short Beam Shear	D-2344	psi/MPa	4,500/31
Bearing Stress, <i>LW</i>	D-953	psi/MPa	30,000/206.8
Izod Impact, <i>LW</i>	D-256	ft-lbs/in/J-mm	25/1.33
Izod Impact, <i>CW</i>	D-256	ft-lbs/in/J-mm	4/0.21

Physical Properties	ASTM	Units	Value
Barcol Hardness	D-2583	-	45
24 Hour Water Absorption	D-570	% Max	0.45
Density	D-792	lbs/in <sup>3</sup> /gm/cc	0.0686/2
Coeff. of Thermal Expansion, <i>LW</i>	D-696	10 <sup>-6</sup> in/in/°C	8
		10 <sup>-6</sup> mm/mm/°C	8

Electrical Properties	ASTM	Units	Value
Arc Resistance, <i>LW</i>	D-495	sec	120
Dielectric Strength, <i>LW</i>	D-149	kv/in	35
Dielectric Strength, <i>PF</i>	D-149	volts/mil	200
Dielectric Constant, <i>PF</i>	D-150	@60hz	5

Flammability Properties	ASTM	Units	Value
Tunnel Test	E-84	Flame Spread	25 max
Flammability	D-635	-	Non-burning



## Safgrate Ladder and Cage Systems

Safgrate fiberglass ladders and ladder cages are used throughout a wide range of industries. Our ladders are structurally strong as metal ladder systems providing a corrosion resistant and non-conductive alternative.

### Materials of Construction

Safgrate ladders and ladder cage systems are produced using premium grade isothalic polyester resin system with flame retardant and ultraviolet (UV) inhibitor additives. Our ladder and cage components are standard safety yellow. The rungs are a pultruded solid fiberglass polyester rod with a fluted, non-skid surface.

### Applications

Our Safgrate ladder and ladder cage systems are designed for use as:

- Wall Mount Ladders
- Base/Floor Mount Ladders
- Walk-Through Ladders with Return
- Side Mount Cage
- Walk-Through Cage with Return

Safgrate ladder and ladder/cage systems come in lengths from 6' to 24'.

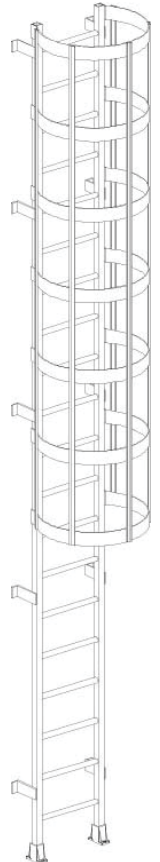

FRP Ladder Model Logic				
Part Number	Width (in)	Height (ft)	Color	Resin Type
PFL18-PP-Y-6	18	6	Yellow	Premium Polyester
PFL18-PP-Y-10	18	10	Yellow	Premium Polyester
PFL18-PP-Y-14	18	14	Yellow	Premium Polyester
PFL18-PP-Y-16	18	16	Yellow	Premium Polyester
FRP Ladder Options			Example	
Cage height (ft)		C-XX	PFL18-PP-Y-10-C4	



## Metal Stair Treads

### Bar Abrasive Treads



Single Part



Two Part

- Extruded Aluminum Base
- Aluminum oxide silicon carbide abrasive locked into individual channels
- 10 Different color selections
- Easy to install
- Ideal for indoor and outdoor use
- Available in single or two part installation
- Factory cut to custom specifications

### Full Abrasive Treads



Single Part

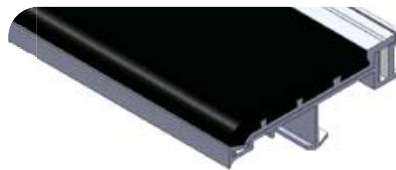

Two Part

- Extruded Aluminum Base
- Full surface aluminum oxide silicon carbide abrasive locked into sub-channels
- 10 Different color selections
- Easy to install
- Ideal for indoor and outdoor use
- Available in single or two part installation
- Factory cut to custom specifications

### Renovation Treads

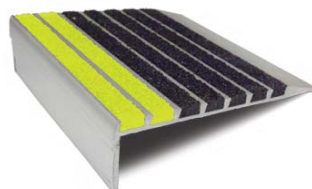

Vision Line option\*\*

- Extruded Aluminum Base
- Aluminum oxide silicon carbide abrasive locked into channels
- Ideal for restoration of stairs
- 10 Different color selections
- Easy to install
- Great for indoor and outdoor use
- Factory cut to custom specifications

### Cast Metal Treads

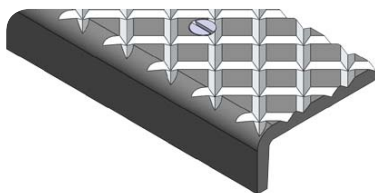

Cast Aluminum

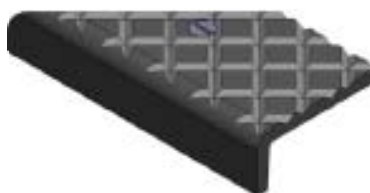

Cast Iron

- Cast Aluminum & Iron Treads
- Sand cast surface finish
- Ideal for heavy traffic areas
- Will last the lifetime of the building
- Easy to install
- Great for indoor and outdoor use
- Factory cut to custom specifications



## Bar Abrasive Treads

### Concrete Poured Stair - Short Nosing

1-7/8" width



M3301

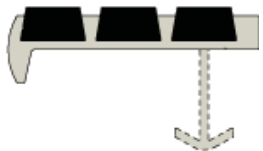

M3311

3" width



M3501

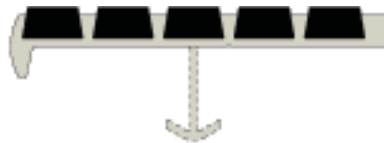

M3511

4" width



M3701



M3711

### Ramps & Walkways

1-3/8" width



M1201

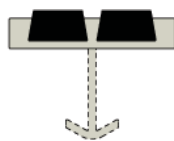

M1211

3" width



M1501

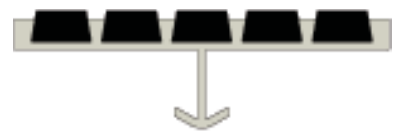

M1511

### Color Options



To order a color other than black, please include the color code after the product part number.  
Ex: M3301-C1

ADA and OSHA Approved  
Barrier Free Compliant  
Anti-Slip Safety Stair Treads



## Bar Abrasive Treads

### Steel Pan & Wood Stair - Long Nosing

1-7/8" width

3" width



M4301



M4501

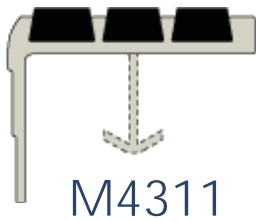

M4311



M4511

### Steel Pan Sloped Stair - Long Angle Nosing

1-7/8" width

3" width



M8301



M8501

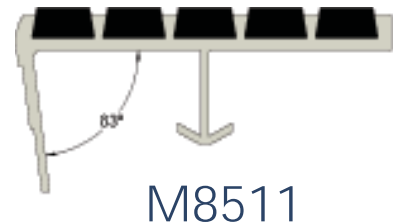

M8511

### Color Options



To order a color other than black, please include the color code after the product part number.



Ex: M3301-C1

ADA and OSHA Approved  
Barrier Free Compliant  
Anti-Slip Safety Stair Treads

## Bar Abrasive Treads

### Steel Pan & Concrete Stair - Short Tip Nosing

1-7/8" width

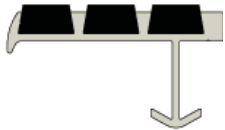

M9311

3" width



M9511

4" width



M9711

### Two Part

3-3/8" width

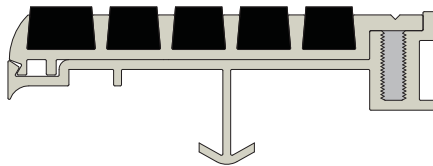

MTP311

### Color Options



To order a color other than black, please include the color code after the product part number.  
Ex: M3301-C1

ADA and OSHA Approved  
Barrier Free Compliant  
Anti-Slip Safety Stair Treads

## Full Abrasive Treads

### Concrete Poured Stair - Short Nosing

2-1/8" width



MFA201D

3-1/8" width



MFA301D

4" width



MFA401D

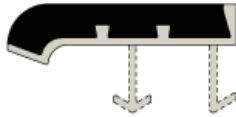

MFA211D



MFA311D



MFA411D

### Steel Pan & Concrete Stair - Short Tip Nosing

1-3/8" width

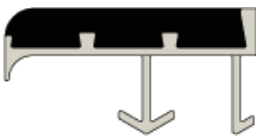

MBF211D

3" width

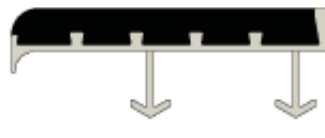

MBF311D

4" width

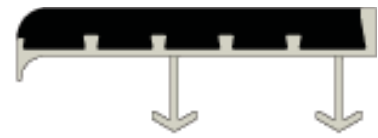

MBF411D

### Two Part

3-3/8" width

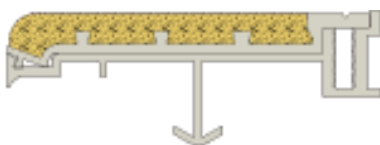

MBFTP311

ADA and OSHA Approved  
Barrier Free Compliant  
Anti-Slip Safety Stair Treads

## Full Abrasive Treads

### Steel Pan & Wood Stair - Long Nosing

2-1/8" width



MFAL201

3-1/8" width



MFAL301

4-1/8" width



MFAL401

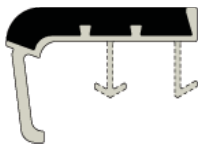

MFAL211

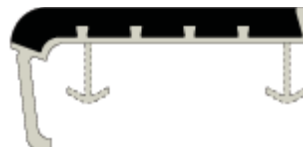

MFAL311

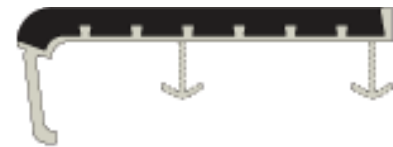

MFAL411

### Ramps & Walkways - Title 24

2-1/4" width



M24

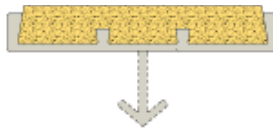

M24H

### Color Options



To order a color other than black, please include the color code after the product part number.



Ex: M3301-C1

ADA and OSHA Approved  
Barrier Free Compliant  
Anti-Slip Safety Stair Treads

## Renovation Treads

### Steel Pan Sloped Stair - Long Nosing

5" width



M4702



SM4702

9" width



M500R



SM500R

11" width



M505R



SM505R

### Color Options



C1

C2

C3

C4

To order a color other than black, please include the color code after the product part number.



C5

C6

C7

C8

C9

Ex: M3301-C1

ADA and OSHA Approved  
Barrier Free Compliant  
Anti-Slip Safety Stair Treads



## Cast Metal Treads

### Concrete Poured Stair - Short Nosing



M801

- Available in both Cast Aluminum and Cast Iron
- Most commonly used cast tread
- Available in 2", 3" & 4" widths
- Easy to install
- Ideal for heavy traffic areas
- Factory cut to custom specifications

### Steel Pan Stair - Long Nosing

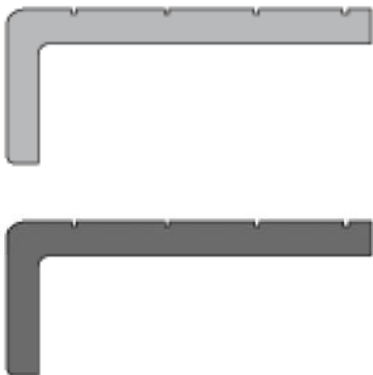

M816

- Available in both Cast Aluminum and Cast Iron
- Available in 3" & 4" widths
- 1" Nosing
- Easy to install
- Ideal for heavy traffic areas
- Factory cut to custom specifications

### Anchor Options

#### Wing

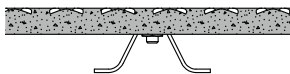

- Countersunk Holes
- Stainless Steel bolt/nut
- 2-1/2" wing-span
- Industry Standard

#### Cast-on-Anchor

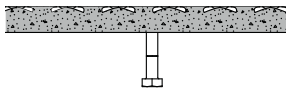

- Bolt precast into tread
- 1-1/4" bolt length
- Quick and easy to install

ADA and OSHA Approved  
Barrier Free Compliant  
Anti-Slip Safety Stair Treads





Modern Engineered Products, Inc. is a manufacturer's representative and distributor of a diverse line of products serving multiple industries since 1991. MEP is the parent company of; North American Sensors Corporation, North American Grating and Pressure Switches Inc. MEP does all the marketing and sales for these divisions.  
[www.mepinc.net](http://www.mepinc.net)



North American Sensors Corporation was established in 1991. N.A.S.C. specializes in the manufacture of level, pressure and temperature sensors. At N.A.S.C. we strive to meet all of your pressure, level and temperature measurement needs. Made in the USA.  
[www.northamericansensors.com](http://www.northamericansensors.com)



Pressure Switches Inc, was established in 1989 as a manufacturer of industrial grade pressure switch products. PSI manufactures six series of pressure switches to serve your needs. PSI's line of pressure switches is diverse enough to meet your differential, vacuum, pneumatic and hazardous locations requirements. Made in the USA.  
[www.pressureswitches.com](http://www.pressureswitches.com)



North American Grating is a wholesale supplier of fiberglass grating and FRP structural material located in Covington, Louisiana. We are confident we can assist you with your FRP needs because, we have over two decades of experience in the fiberglass industry. We value our customer relationships and strive to offer a level of service that exceeds the industry standard.  
[www.northamericangrating.com](http://www.northamericangrating.com)

**Note: Custom fabrication services available.**